



# GSC 120 - 24

| 24 HR Gas Station Canopy |

## Construction

Aluminum alloy housing  
Heat Wick® heat sink technology  
10 Year Warranty on housing  
Acrylic lens  
IP 56

## Operating Ranges

Operating temperature range of -40 to 140°F  
Operating humidity range of 10 - 99%

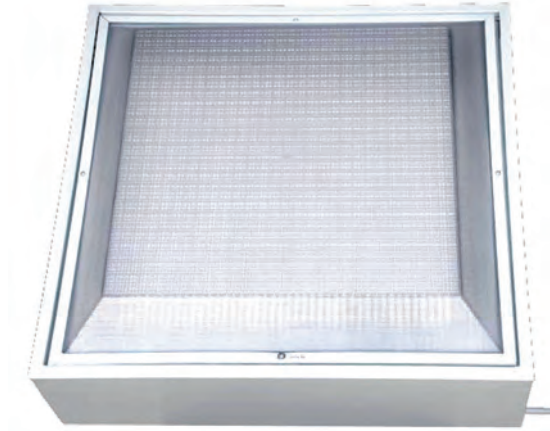

## CLGL Design

No hazardous substances. ROHS compliant.  
No mercury. No lead.  
24 Hour Run Hard Design

## Applications

Parking Garages, Petrol Lighting, Outdoor Lighting,  
& Canopy Lighting

## Model Details

Wattage	120
Lumens	7800
Approximate Weight	28 lbs. 2 oz.
Warranty	5 Year

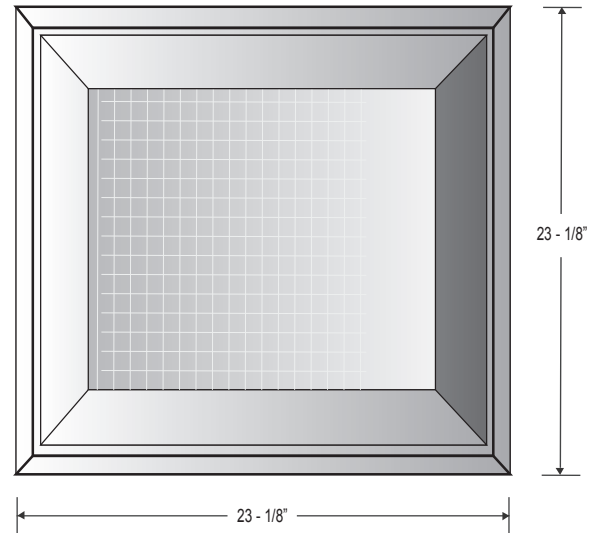
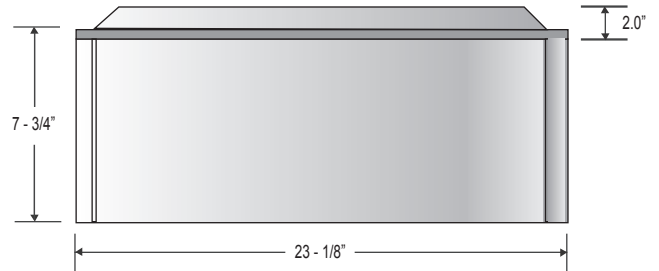

## Ordering Information

Please Fill Out Below

Model : GSC 120 - 24

### Lamp Quantity

### Voltage

90 - 260V

90 - 260V



### Lamp Color

5500K

5000K - 6000K

Distributed by Stouch Lighting

525 Turner Industrial Way  Aston, PA 19014

p: 866.964.8559  f: 610.494.6138  e: info@stouchlighting.com  w: www.stouchlighting.com