



# STL 80

| 250 - 400W HID Equivalent |

## Construction

Weatherproof housing/finish  
10 Year Warranty on housing  
Poly carb drop down lens  
Tool-less entry  
Heat Wick® heat sink technology

## Operating Ranges

Operating temperature range of -40 to 140°F  
Operating humidity range of 10-99%

## CLGL Design

No hazardous substances. ROHS compliant.  
No Mercury. No Lead. 100% Recyclable Head

## Applications

Street Lighting, Parking Lot Lighting, Area Lighting,  
Perimeter and Security Lighting

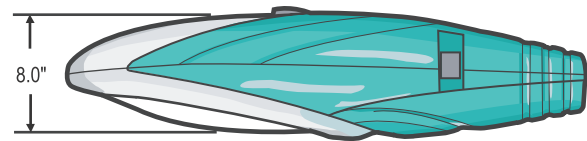
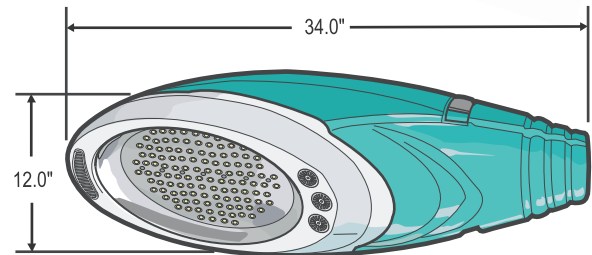
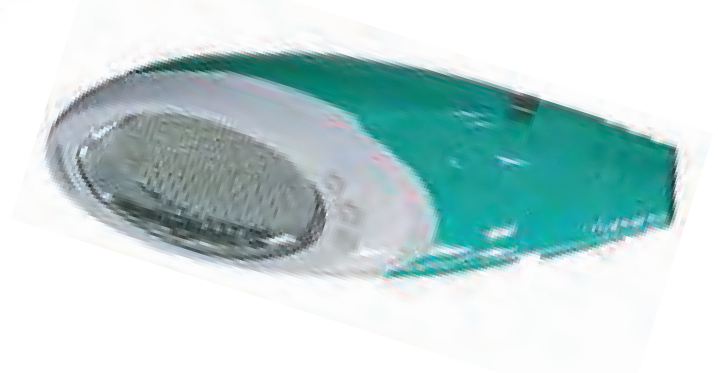

## Model Details

Wattage	88
Lumens	6810
Approximate Weight	6 lbs. 8 oz.
Warranty	7 Year

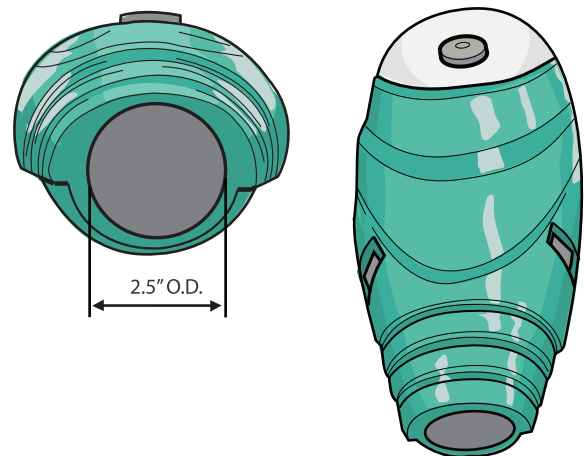

## Ordering Information

Please Fill Out Below

Model : STL 80

**Head Quantity**

**Glass / Poly Carb**

Photo Cell or No Photo Cell  
(Y/N)

**Voltage**

90V-264V, 277V\*, 347V\*  
\*using a step down transformer

**Lamp Color**

5500K

Distributed by Stouch Lighting

525 Turner Industrial Way Aston, PA 19014

p: 866.964.8559 f: 610.494.6138 e: info@stouchlighting.com w: www.stouchlighting.com