



# STL RET

| LED Street Light Retrofit |

## Construction

Mogul or Edison Base  
Heat Wick® heat sink technology

## Operating Ranges

Operating temperature range of -40 to 140°F  
Operating humidity range of 10-99%  
13' to 15' application heights  
150W HID or lower replacement

## CLGL Design

No hazardous substances. ROHS compliant.  
No Mercury. No Lead.

## Applications

Street Lighting, Parking Lot Lighting, Area Lighting,  
Perimeter and Security Lighting

## Model Details

Wattage	31
Lumens	2077
Approximate Weight	3 lbs. 9 oz.
Warranty	5 Year

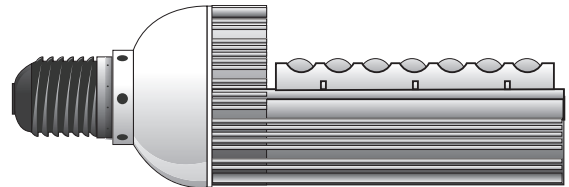
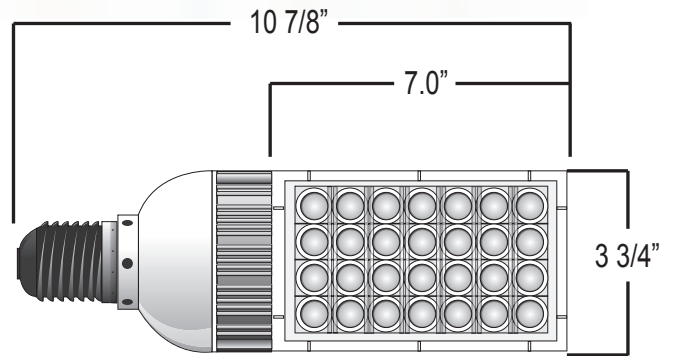

## Ordering Information

Please Fill Out Below

Model : STLRET

**Quantity**

**Lamp Base**

E27 or E40

**Voltage**



90V-265V, 277V\*, 347V\*  
\*using a step down transformer

**Lamp Color**

5000K-6000K  
custom CCT ranges available

Distributed by Stouch Lighting

525 Turner Industrial Way  Aston, PA 19014

p: 866.964.8559  f: 610.494.6138  e: info@stouchlighting.com  w: www.stouchlighting.com