



STLX8

| 700 - 1000W HID Equivalent |

Construction

Aluminum housing. All weather design.
Patented roadway optics
10 Year Warranty on housing
5500K and IP 65
Heat Wick® heat sink technology

Operating Ranges

Operating temperature range of -40 to 140°F
Operating humidity range of 10-99%



CLGL Design

No hazardous substances. ROHS compliant.
No Mercury. No Lead.

Applications

Streets, Parking Lots, Areas,
Perimeters and Security Lighting

Model Details

Wattage	281
Lumens	13,408
Approximate Weight	24 lbs. 1 oz.
Warranty	7 Year

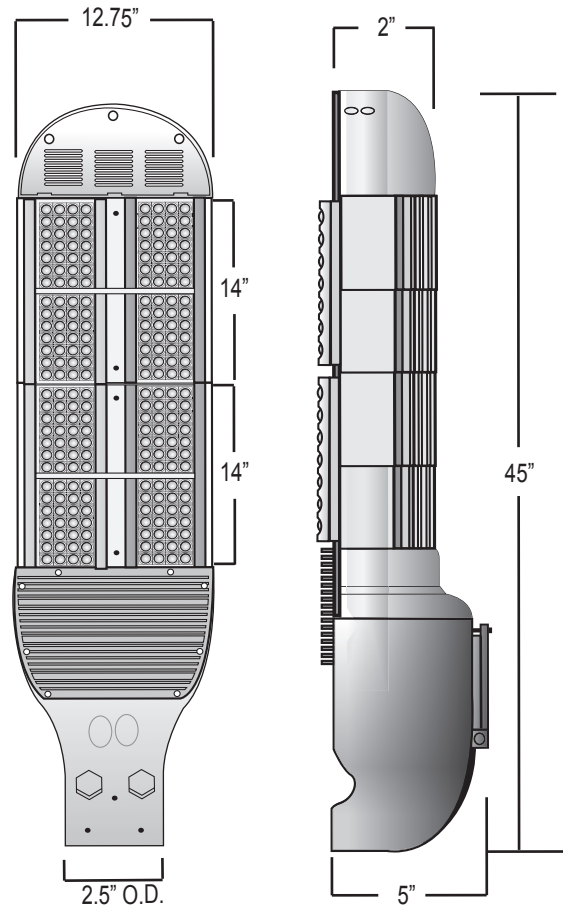

Ordering Information

Please Fill Out Below

Model : STLX8

Lamp Quantity

Photo Cell

Photo Cell or No Photo Cell
(Y/N)

Voltage

90V-320V

Lamp Color

5500K
custom ranges available

Distributed by Stouch Lighting

525 Turner Industrial Way Aston, PA 19014

p: 866.964.8559 f: 610.494.6138 e: info@stouchlighting.com w: www.stouchlighting.com